

ERHARD needle valves

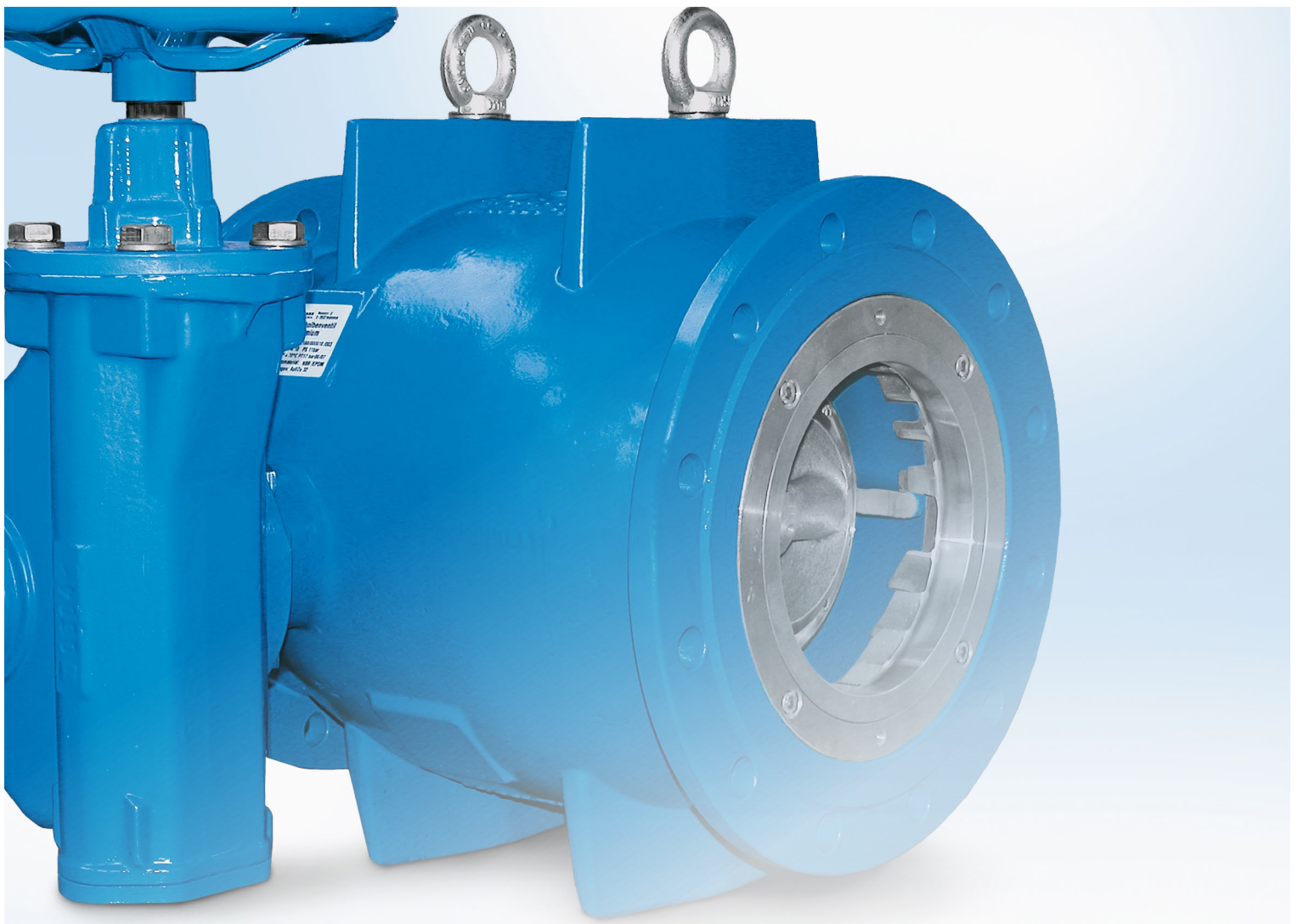

NEEDLE VALVES – FOR SAFE AND EXACT CONTROL

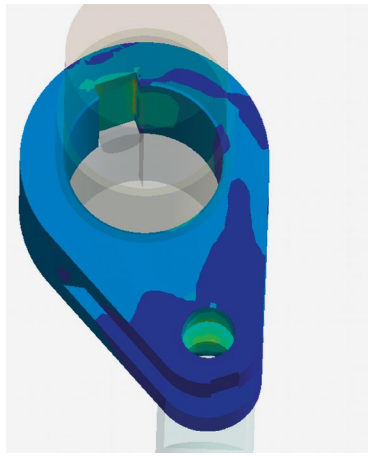

All the components of the ERHARD RKV needle valves are designed on the basis of decades of experience. At the same time, state of the art techniques are used in the development, e. g. the finite elements methods (FEM). It visualises the stress curve in the whole component – here in the gearbox crank of a needle valve – and colours it according to the existing stress: blue stands for low stresses, orange or red for high stresses. This makes it easy to see whether and in which part of the component stress peaks occur and where changes are necessary to increase strength.

Needle valves are the suitable valve to use whenever pressure heads or flow rates need to be safely and reliably reduced and controlled. They are used for two main tasks:

- By restricting the cross-section, a change in flow rate, flow velocity and pressure is forced, which results to higher stress in the valve. The valve must therefore be designed so that potential cavitation cannot cause any damage whatsoever.
- To be able to control the pressure and flow precisely and finely, the control valve's control characteristics must be as linear as possible over the whole opening range.

Thanks to their well thought out design, ERHARD needle valves fulfil these requirements to the greatest possible degree and are therefore the ideal valve for numerous control tasks. Because even if butterfly valves and gate valves are used for such tasks in individual cases in practice, due to their design as an optimum shut-off device for "OPEN/CLOSED" operation, but they are not suitable for continuous use as a control valve.

New challenges ...

The production and operation of control valves requires sophisticated know-how, to enable the differentiated requirements to be fulfilled:

- International standards, approvals and test regulations set the highest quality requirements.
- The increased cost of energy requires optimum flow performance with minimum pressure losses to ensure economic operation.
- And last but not least, long life valves and low maintenance costs ensure that the personnel costs necessary for operation are minimised. After all, nowadays, all the costs incurred over the whole life of the valve (life cycle costs) play a decisive role in the choice of product.

... and the solutions from ERHARD

The wide range of ERHARD needle valves fills these requirements in a particular way. They are especially suitable for drinking water, raw water and air. Their typical applications include use as:

- Pump start-up and control valve
- Reservoir inlet
- Control device in the bottom outlet valve of dams (with or without venting)
- Control device in the inlet and bypass of turbines
- Safety device in the bypass outlet of turbines for quick opening
- Control and simultaneous safety device in pipe systems (e. g. pump pressure pipes)

Innovative and customer-focused product development, state of the art engineering, production and assembly technology and continuous quality assurance throughout take place at ERHARD, concentrated in one location – for top quality "Made in Germany" before, during and after installation.

PROPERTIES AND ADVANTAGES AT A GLANCE

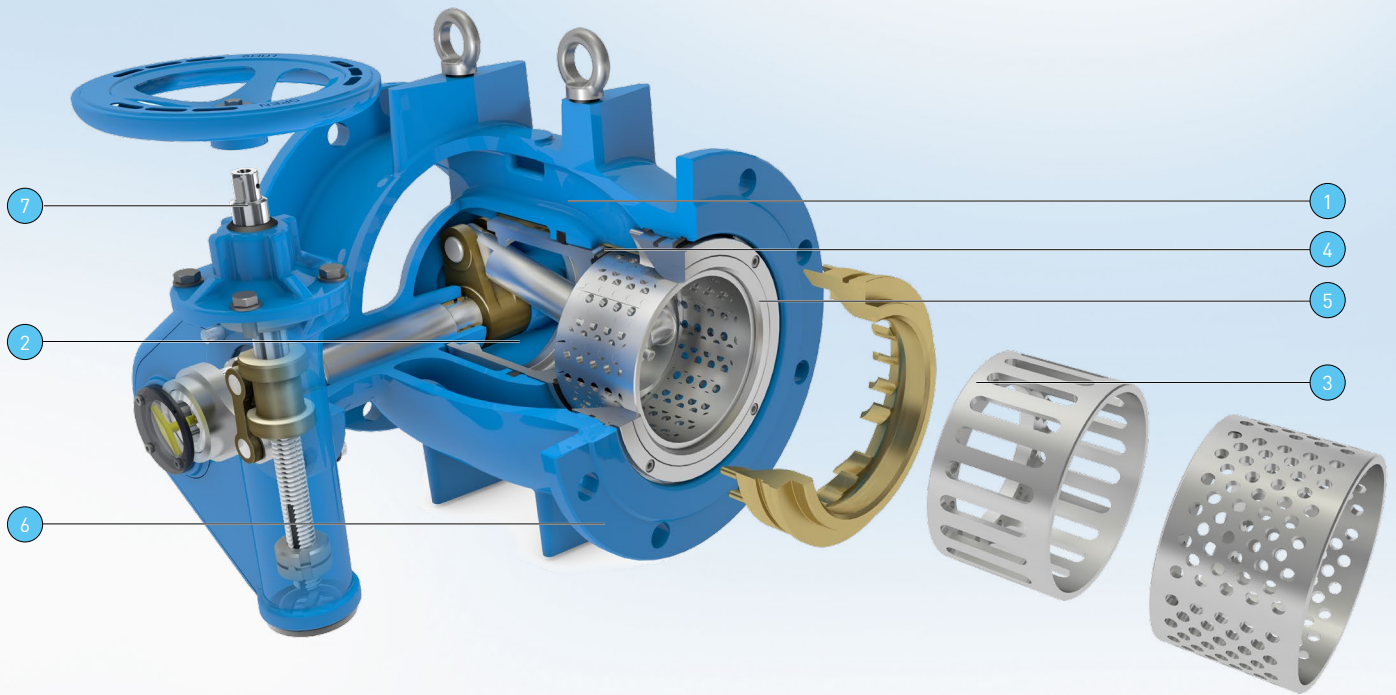

No.	Advantage	Property	Info on page ...
1	Economic use and protection against stagnant water	Optimised flow performance and flow guiding for practical Zeta values, minimum pressure losses when fully opened	10
2	Precisely controllable flow characteristics	Control range up to 96 % and slider crank mechanism with precisely adjusted characteristic curve	12
3	Safe and reliable pressure reduction to prevent cavitation damage	Control inserts for every application: seat ring, vaned ring, slotted cylinder, perforated cylinder and other special inserts	6
4	Minimum gasket wear	Wide main gasket in the cavitation-free space and additional shaft seal	11
5	Long life of the valve	Four hard-faced guides and optimised corrosion protection with EKB fusion bonded epoxy	8 and 12
6	Wide range of pressure ratings, nominal sizes and designs	Adapted solutions for numerous special applications	9, 13 and 14
7	Perfect adaptation to all installation situations	Standardised connections for all types of actuators	17

PROVEN ENGINEERING FOR DIVERSE TASKS



Improper continuous use of butterfly valves as a control valve can result in dramatic material damage, as in this valve opened by 5° after a year in seawater.

Needle valves have been part of ERHARD's extensive product range for more than 100 years. This experience is reflected in thousands of installed valves which have proven their worth in daily use. Product innovations developed by ERHARD have therefore often been copied and today form the standard in the needle valve market. But only the combination of well thought through details and decades development, production, installation and maintenance experience results in the perfect original, the ERHARD RKV needle valve.

The principle of the needle valve

The cross-section in the valve is reduced to control pressure ratings and flow rates. But while asymmetrical cross-sections result in gate valves or valves (e. g. if the gate valve is closed from above), in the needle valve a ring-shaped cross-section always exists in every position, which therefore enables a linear control curve over a wide range.

Initially the cross-section is steadily reduced from the inlet up to the restrictor cross-section and the flow is guided along in a geometrically optimised shape on the teardrop shaped internal body. A sliding piston is axially guided inside the internal body for flexible and precise change in cross-section. Its linear movement results from conversion of the rotary movement of the actuator shaft by the internal slider crank mechanism and ensures a defined ring-shaped cross-section in every position. Depending on the intended use, various control inserts are mounted on the piston, which split the flow into individual flow filaments for conversion of the energy. These filaments do not hit each other until they reach the middle of the valve or pipe, which reliably prevents cavitation damage to the valve.

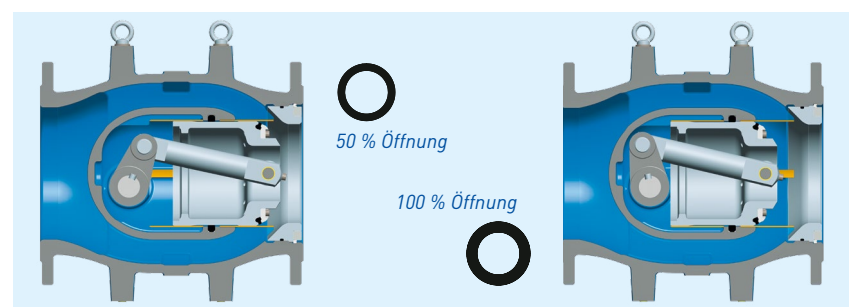

The design of the ERHARD RKV needle valve ensures a ring-shaped cross-section in every piston position and therefore safe, reliable energy conversion in the middle of the valve, which significantly minimises the effects of cavitation.



ERHARD needle valves can be used for numerous tasks – from the bottom outlet valve of dams through to complex control tasks.

Designs for every purpose

ERHARD RKV needle valves, depending on their nominal size, are available as a one-piece type (e. g. ERHARD RKV Premium needle valve) or a multipart type. Depending on the tasks to be fulfilled, a suitable control insert can be used: from a seat ring and a vaned ring to slotted cylinder and perforated cylinder through to other special types of control inserts.

ERHARD RKV needle valves can be used in numerous control circuits, e. g.:

- Downstream pressure control
- Upstream pressure control
- Reservoir control
- Flow control

Attention must also be paid to venting, depending on the positioning of the needle valve. For example, if it is positioned directly at the end of a pipe in a bottom outlet or a turbine bypass and is equipped with a vaned ring, the energy conversion takes place by splitting up the water jet and intensive mixing with the ambient air, so that separate venting is not necessary. If on the other hand the pipe is continued downstream of the needle valve up to the outlet into the open, an appropriate designed jump in nominal size and a venting pipe must be provided to ensure adequate air supply downstream of the seat, otherwise enormous cavitation and impelling forces can result in damage. Your ERHARD team will provide you with competent and comprehensive design advice.

Constricted version (RKVE)

In special installation situations, apart from the standard type, a constricted version can also be used, whose nominal size is smaller than the nominal size of the pipe positioned upstream of it and which is realised with correspondingly shorter face-to-face dimension. If high pressure ratings have to be dissipated, without the focus being on maximum flow, or if confined space conditions exist, this version is also an economically interesting option.



Depending on the nominal size and design, ERHARD RKV needle valves are available as single or multipart types.

SAFE PRESSURE REDUCTION AND CAVITATION UNDER CONTROL

Cavitation risk factor

Depending on the pressure and velocity conditions, eddy, turbulence and cavitation zones can occur in pipes and fittings which can cause vibrations, oscillations and, under certain operating conditions, can even cause material damage.

Cavitation occurs if vapour bubbles form and implode in the pipe. According to Bernoulli's law, the total energy of a flowing medium is always the same; and therefore the sum of the potential, pressure, velocity (kinetic) and lost (dissipated) energy is constant. If the flow velocity now increases at a constriction, e. g. a needle valve, the pressure energy simultaneously falls. If the pressure falls below the medium's saturation vapour pressure, vapour bubbles form which further deform after the constriction. Downstream of the constriction the velocity reduces again and the pressure increases, so that the bubbles finally implode. The microjet produced as a result can hit components with high velocities and remove component material where they impact. Therefore, a decisive factor for use of the needle valve is for the energy conversion to take place in the middle of the valve, which is ensured by the design of the flow profile and special control inserts.

Safe and reliable pressure reduction and cavitation under control

ERHARD needle valves are fitted with a seat ring as a basic standard: this is the suitable solution for low pressure loss coefficients (K-values) or for the medium air. For all other applications, it makes sense to use special control inserts matched to the respective operating conditions; the design of these inserts is only one example of ERHARD's extensive know-how for control tasks. They ensure that the velocity increase which occurs when the cross-section is changed do not result in cavitation damage. Choice of the correct control insert depends on the operating conditions, the differential pressure and the resulting cavitation behaviour. We would be pleased to advise you.

Vaned ring

The vaned ring is a ring with uniformly arranged blades, which split the flow into individual flow filaments just before the discharge and due to their shape set them in a spiral movement. The outer flow is pressed against the wall of the outlet part or the downstream pipe so that the cavitation bubbles which occur do not come anywhere near the wall, but instead are bundled together to form a "pigtail" in the middle of the pipe. There they are dissipated without causing any damage. Vaned ring are used for average pressure differences and in back-pressure.

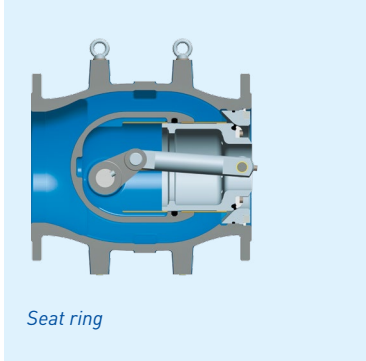
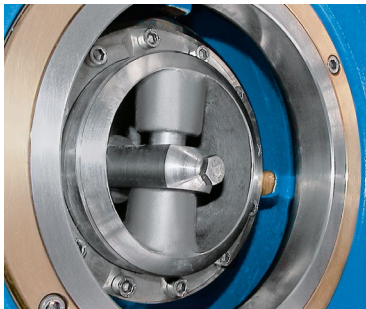

Seat ring

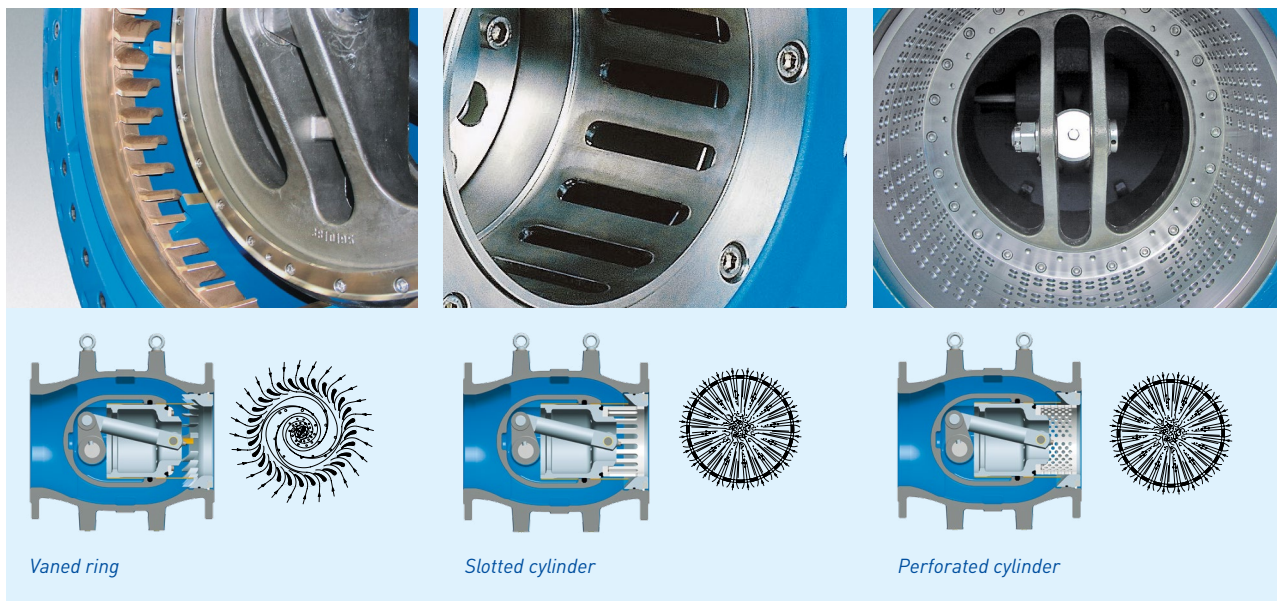

Slotted cylinder

Slotted cylinders, on the other hand, are the suitable design for high pressure differences. This attachment extends the end piston in a similar way to a pipe and is especially designed to the specific operating conditions. The water jets flowing from the outside to the inside through the slots are split up at the slots and reach a high velocity. Then, in the material free centre of the cylinder, they collide with the jets emerging from the slots on the opposite side. On collision part of the kinetic energy is converted into pressure energy. The cavitation bubbles occurring at the slots and dragged along with the jets are dissipated by this increase in pressure in the centre of the flow without causing any damage.

Perforated cylinder

The perforated cylinder, which functions in the same way as the slotted cylinder but has higher zeta values, is also suitable for high pressure differences.

Other control inserts available

- Special slotted cylinder
- Special perforated cylinder
- Throttle ring especially for energy recovery systems
- Control attachments for pump test rig
- Control inserts for bottom outlets

HIGH MATERIAL QUALITY OPTIMALLY PROTECTED



All ERHARD RKV needle valves are coated with ERHARD EKB fusion bonded epoxy as a standard feature. This epoxy plastic coating, applied using powder coating methods, is one of the most frequently used corrosion protection methods. The cast parts are first shot-blasted with special granulate to make them metallically bright [1]. The coating is then applied with a precisely defined thickness in the electrostatic power station and is fusion bonded at 210 °C.

The standard coat thickness is at least 250 µm, coat thicknesses up to 500 µm are possible. The plant operates with state of the art technology and fulfils the test conditions of the GSK Quality Association for Heavy Duty Corrosion Protection of Powder Coated Valves and Fittings with quality assurance RAL-GZ 662. ERHARD EKB fusion bonded epoxy is applied to large valves using a wet method and two coats: The electrostatic wet coating with low-solvent 2-component epoxy plastic is applied to a cathodic basic protection (primer) [2]. The final cross-linking to produce heavy-duty corrosion protection in accordance with DIN 30677-2 takes place in the heat channel. ERHARD EKB fusion bonded epoxy is physiologically safe for drinking water and, for example, has confirmed test certificates from the DVGW-Forschungsstelle TZW Karlsruhe, the Hygieneinstitut Gelsenkirchen and the WRAS (WRc) in Great Britain.

Other special coatings are available for particular requirements, e. g. EPC coating (epoxy polymer ceramic) with ceramic reinforcing fillers, particularly suitable for abrasive media or seawater.

THE PERFECT SOLUTION, EVEN FOR SPECIAL REQUIREMENTS

ERHARD RKV needle valves are suitable for classic uses such as the bottom outlet control and safety devices in turbines and pipes as well as for numerous other specially applications:

- Shut-off device in pipes with high operating pressure and high flow velocities
- Pump start-up valve
- Return flow prevention for pumps with drop weight
- Piston type check valve
- Safety overflow valve for removing impermissible pressure increases in the pipe system (free of auxiliary power)
- Bypass outlet surge protection in pipelines
- Pipe burst protection
- Turbine bypass
- Turbine control
- Filling valve for high pressures and pipe discharging in the open air or for large pipelines
- Flushing/purging valve
- Pump test rig
- Air flow rate control in aeration tanks
- Industrial applications

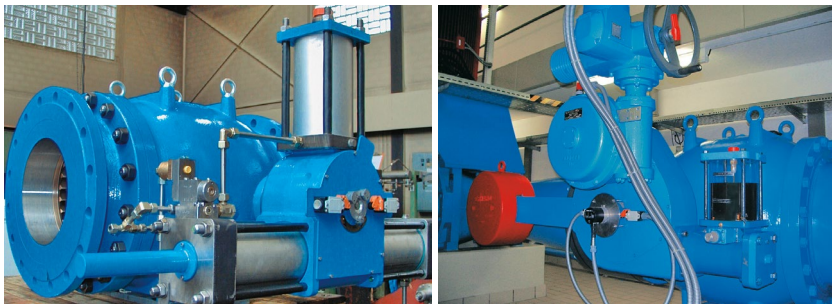

An ERHARD needle valve with ingenious control engineering was installed in the secondary turbine outlet during the modernisation of a River Danube power station. The valve operates autonomously via its own medium control and if the turbines are shut down, pressure surges and therefore risk to the plant are reliably avoided.

In storage operation of large drinking water supply plants, geodetic energy is often available virtually free of charge. Reliable valves suitable for use with drinking water are necessary in the parts of the plant in which energy recovery is possible. An example of the use of ERHARD valves for these application cases is a needle valve DN 600 PN 16 with weight-loaded hydraulic actuator and magnetic clutch. Up to 1,200 l/s have to be safely controlled upstream of the turbine and must be stopped reliably and without surges if the turbine is shut down. In this application case, ERHARD proves to be a competent partner for the project planning and design of valves.

THE ADVANTAGES OF THE NEW ERHARD RKV PREMIUM NEEDLE VALVE



ERHARD engineers implemented numerous innovative ideas in practice in the development of the new ERHARD RKV Premium needle valve (DN 100-300, PN 10/16/25) – for greater economic efficiency, greater operating safety, longer life and improved controllability of the valve.

Optimised flow guidance – a positive result for economic efficiency

The flow channel of the ERHARD RKV Premium needle valve was redesigned on the basis of years of planning and application experience and numerous practical tests.

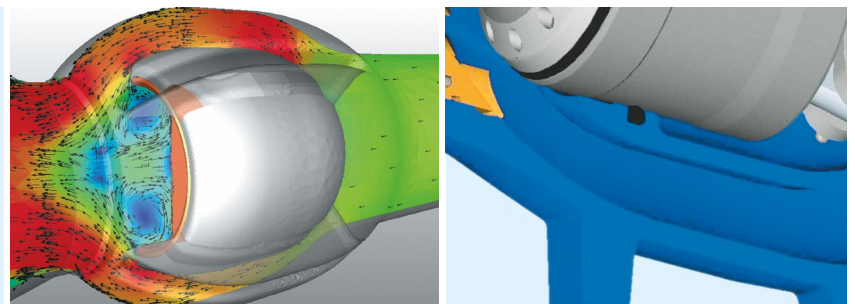

Numerous practical tests and series of measurements in the ERHARD test centre and simulations of the flow performance with state of the art 3D CAD systems confirmed the optimised flow pattern. At the same time, the hydraulic characteristics were determined and continuous tests were performed. Due to high-precision production, these values can then be realised in practice too.

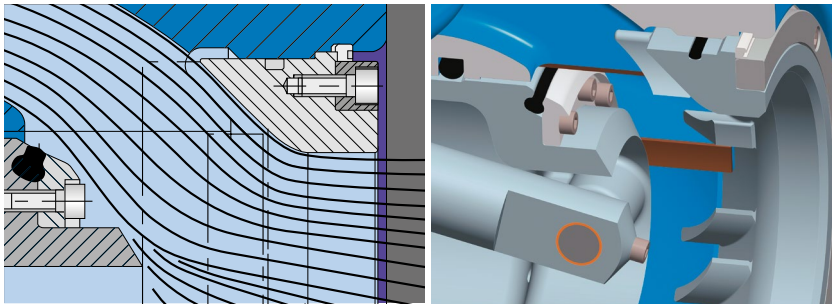

The main seal, up to 15 mm wide, sits on the piston outside the zone at risk of cavitation and is embedded, corrosion-proof, in stainless steel.

Optimum design of the sealing and outlet parts, flow-optimised component shapes and freely selectable control inserts for the user, e. g. smooth seat rings, vaned rings, slotted cylinders and perforated cylinders given the lowest zeta values and enable cost-effective operation, as the pressure loss is lower. Compared to the proven and tested predecessor model, the values were further improved by up to 50 % and therefore enter a new dimension of economic efficiency.

The ingenious flow guiding within the needle valve also reliably prevents the formation of stagnant water. This ensures a high degree of cleanliness and sterility at all times, especially in the sensitive drinking water sector. Further optimisation in the corrosion protection details supplements the high-quality product features.

Absolutely minimum gasket wear – a positive gain for operating safety

The wide main gasket of the ERHARD RKV Premium needle valve is located safely in the hydraulically uncritical pressure zone and therefore in the cavitation-free space of the control valve. It's sealing surface is up to 15 mm wide and is completely embedded in a stainless steel chamber and is therefore protected against corrosion on all sides. The piston seal is designed as a solid O-ring with a proven and tested design with undercut piston. All these features together form an optimum sealing system with minimum wear.

The inner shaft seal has also been further improved and an additional sealing element has been added, which contributes to optimisation of the corrosion protection and at the same time additionally helps to prevent stagnant water.

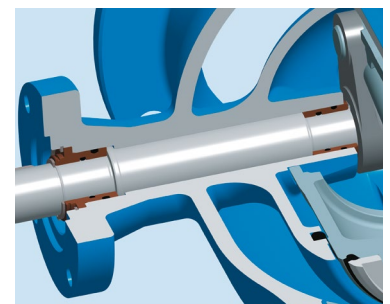

The additional shaft seal on the inside improves the corrosion protection and prevents stagnant water.

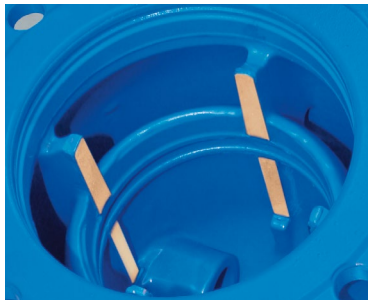
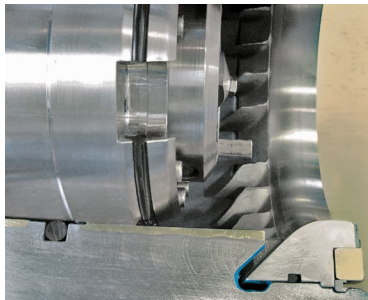

The four hard-faced guides ensure permanently uniform movement of the piston.

In conjunction with the ERHARD SKG slider crank mechanism, the result is a control range of 96 %.

Four hard-faced guides – a positive result for longer life

By using four wide guide strips, the force of the weight of the piston acts vertically and thanks to the larger contact surface is also uniformly spread over the guide strips, while, e. g. if only three strips are used, non-uniform attrition and far greater wear occurs.

The material used is a bronze-aluminium alloy, which has proven its worth for decades in high-pressure needle valves. Its high hardness properties, assured application thickness of around 3 mm and the extreme wear resistance ensure good anti-friction properties – even for decades long operating periods and no matter what the installation position.

The face hardening also further increases corrosion resistance, as the homogeneous material structure does not provide any points for corrosion to attack.

Large linear control range – a positive gain for controllability

While the usual needle valves to date frequently have a dead stroke of up to 18 %, the ERHARD RKV Premium needle valve can be precisely controlled from 4 % opening. It therefore enables optimum control of even the smallest quantities without critical annular clearance and a large control range of up to 96 %.

The optimised control performance is also assisted by the ERHARD SKG slider crank mechanism, used as a standard, which has an optimally adjusted characteristic torque curve and therefore supplies the suitable torque in every opening angle. A slower closing speed near the “closed” position enables extremely soft closing and eliminates the risk of pressure surges.

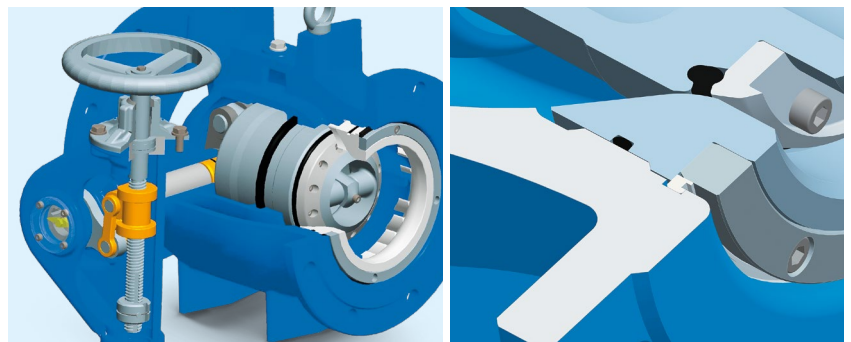

ERHARD RKV NEEDLE VALVES – THE DIMENSIONS TABLE

DN	L	D	D	D	D	h1	h2	h3	h3	e1	e2	e3	u	G	G	G
		PN 10	PN 16	PN 25	PN 40			HR	EA					10	16	25/40
RKV Premium PN 10/16/25																
100	325	-	220	235	-	142	187	222	154	99	214	29	15	60	60	60
125	325	-	250	270	-	142	187	222	154	99	214	29	15	60	60	60
150	350	-	285	300	-	158	203	222	144	116	231	48	15	75	75	75
200	400	340	340	360	-	195	248	244	165	152	288	64	20	120	120	120
250	450	400	400	425	-	234	296	314	233	188	365	80	25	190	190	190
300	500	455	455	485	-	266	322	314	233	224	402	101	25	260	260	260
RKV PN 40																
100	325	-	-	-	235	142	183	250	215	118	205	30	32			59
125	325	-	-	-	270	142	183	250	215	135	205	30	32			59
150	350	-	-	-	300	158	198	260	225	150	225	45	32			73
200	400	-	-	-	375	195	243	260	225	188	265	65	32			117
250	450	-	-	-	450	234	290	310	272	225	322	80	32			188
300	500	-	-	-	515	266	322	310	272	258	357	100	32			262
RKV PN 10/16/25																
350	700	505	520	555	-	280	342	360	292	280	420	67	43	425	450	450
400	800	565	580	620	-	310	372	365	297	310	460	65	42	570	595	595
450	900	615	640	670	-	340	411	404	331	335	510	72	36	780	826	826
500	1000	670	715	730	-	380	451	409	336	370	545	98	43	875	945	945
600	1200	780	840	845	-	460	550	517	416	440	640	84	43	1660	1780	1780
700	1400	895	910	960	-	535	644	566	465	510	720	86	57	2125	2175	2265
800	1600	1015	1025	1085	-	610	719	571	470	585	800	81	52	3250	3295	3445
900	1800	1115	1125	1185	-	700	828	531	430	655	860	112	58	4250	4310	4500
1000	2000	1230	1255	1320	-	785	932	531	430	735	950	120	60	5650	5750	6000
1200	2400	1455	1485	1530	-	950	1118	570	465	870	1110	120	78	8200	8350	8500
RKVE PN 10/16/25																
500	800	670	715	730	-	310	372		297	310	460	65	42			595
600	900	780	840	845	-	380	451		336	310	545	98	43			1065
700	1100	895	910	960	-	460	550		416	440	640	84	43			1930
800	1300	1015	1025	1085	-	535	644		465	510	720	86	57			2465
900	1350	1115	1125	1185	-	610	719		470	585	800	81	52			3695
1000	1600	1230	1255	1320	-	700	828		430	655	860	112	58			4800
1200	1620	1455	1485	1530	-	785	932		430	735	950	120	60			6800

This table contains the dimensions of the standard products in the ERHARD needle valve range. Numerous other designs are available on request for higher pressure ratings or nominal sizes.

Dimensions used:

- L [mm] Face-to-face dimensions
 - D [mm] Flange
 - G [kg] Weight (approximate value, differs depending on the design)
 - u Handwheel revolutions (Open/Closed)
 - HR with handwheel
 - EA with electric rotary actuator (dimensions can vary depending on the actuator manufacturer)
- Other actuator options available on request

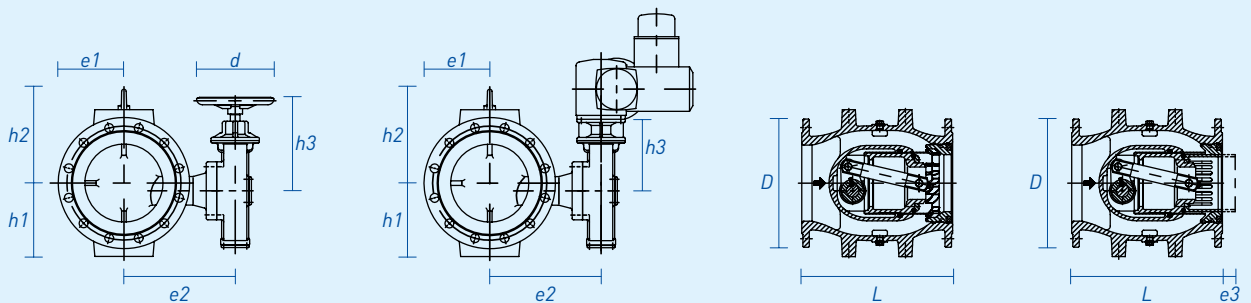

ERHARD RKV NEEDLE VALVES – THE OVERVIEW

Brief specifications: materials and finishes

- **Body:** DN 100-300 and DN 350-1200/PN 25: ductile cast iron EN-JS1050, DN 350-1200/PN 10-16: grey cast iron EN-JL1040
- **Piston guide:** on strips, DN 100-150: stainless steel; DN 200-300: special bronze, highly wear resistant; DN 350-1200 and DN 200-300/PN 40: special brass
- **Vaned ring:** bronze
- **Seat ring, slotted cylinder and perforated cylinder:** stainless steel
- **Gaskets/seals:** elastomer, KTW and W270 approval
- **Piston, shaft, slider crank, push rod, bolt:** stainless steel
- **Gearbox body:** grey cast iron EN-JL1040
- **Gearbox crank:** ductile cast iron EN-JS1050
- **Gearbox stem:** ferritic Cr-Ni steel
- **Stem nut:** special brass
- **Gearbox configuration:** in flow direction “right”; “left” or other arrangements are also possible
- **Corrosion protection of the body parts:** ERHARD EKB fusion bonded epoxy, colour “blue”, coat thickness > 250 µm. Further coating options possible, we would be pleased to advise you

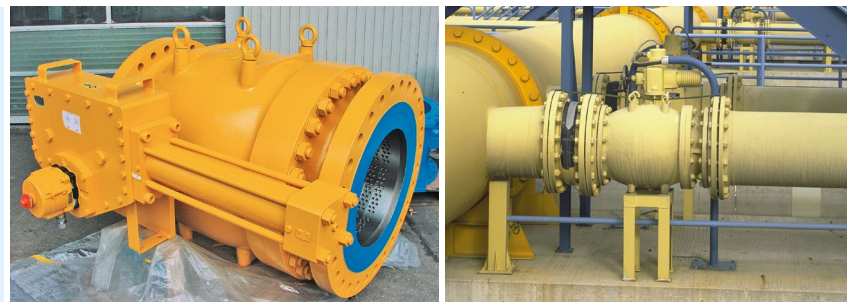

In a drinking water project in the United Arab Emirates, 380,000 m³ extremely precious drinking water are distributed into desert regions daily. The net includes a 180 km pipeline, in which more than 500 ERHARD valves DN 200 to DN 1600 are used, including 32 ERHARD needle valves (DN 700, pump bypass 56 bar, pressure release) with all kinds of different tasks. An especially adapted version in seawater desalination plants ensures continuous, fault-free operation. A task which involves very high standards for the design of the valve.

Apart from their use in the drinking water sector, needle valves are also used in the wastewater sector, e. g. for aeration control in a wastewater treatment plant.

NOTES ON PROJECT PLANNING AND INSTALLATION

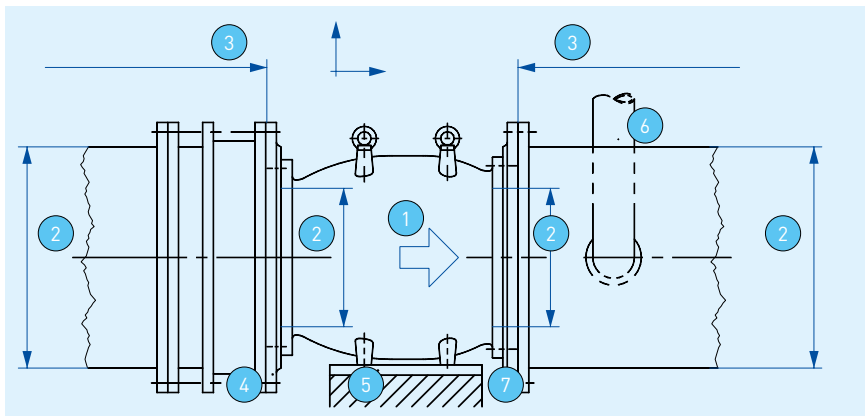

Installation information for the project planning

1. Standard ERHARD RKV needle valves are designed for installation in horizontal or vertical pipes, whereby it is important to ensure that the valve is installed in the pipe according to the flow arrow cast onto the pipe.
2. Nominal size reduction is possible, as ERHARD RKV needle valves are designed according to the flow velocity. We recommend achieving the transition to the pipe nominal size with abrupt extension flanges, which we can supply with the valve if required.
3. To ensure perfect operation, for velocities above 1.5 m/s we recommend a straight pipe section of at least 3-5 x DN upstream and 5-10 x DN downstream of the valve, within which there must be no fittings or valves.
4. If using an adapter or extension section, wherever possible, we recommend installing it in the pipe upstream of the ERHARD RKV needle valve.
5. Needle valves may not be used as the pipe support. The feet cast onto the housings are solely for supporting the valve and not as a pipe fixing point. On request, ERHARD RKV needle valves are supplied with baseplates mounted on the underside.
6. If using ERHARD needle valves in the bottom outlet, an appropriately dimensioned venting device must be installed downstream of the valve, which ERHARD can also supply on request, if the valve does not pump directly into the open air.
7. If on the other hand the valve pumps directly into the open air, a venting device is not necessary. In this case the valve is equipped with an outlet flange only.
8. Inline fixed throttling cylinder can be used for additional pressure reduction for installation in pipes.

Our engineers support you from the planning and design through to assembly – not least with valuable information for correct arrangement and optimum installation of the needle valve. In most cases the advice is based on installation drawings or sketches so that the planned installation location of the ERHARD needle valve can be evaluated. In addition, the following data is required:

- Flow rates $Q_{max.}$ and $Q_{min.}$
- Pressure p_1 upstream of the valve at $Q_{max.}$ and $Q_{min.}$
- Back-pressure p_2 downstream of the valve at $Q_{max.}$ and $Q_{min.}$
- Operating medium, any water analysis available
- Area of use (control device, bottom outlet, etc.)
- Required actuator type
- Operating mode (continuous or short-term operation, etc.)

You can also refer to our "ERHARD needle valve questionnaire" which lists all the data required. They are also used as the basis of the calculations in the calculation program available on CD-ROM.

PERFECT CALCULATION MADE EASY

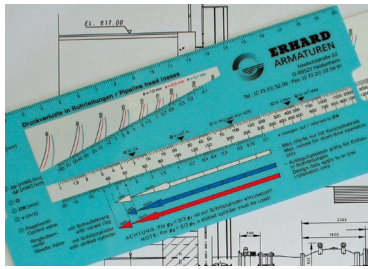

For easy calculation, ERHARD would be pleased to provide you with this practical slide rule or a calculation program on CD-ROM.

ζ values (K-values) or Kvs values can be used to calculate the pressure loss for installation in pipes. Special calculations are necessary for special uses (e. g. as bottom outlet, pump bypass, turbine inlet or bypass valve); our engineers would be pleased to perform these calculations for you.

The Kvs value is the Kv value for a 100 % open valve, which describes the water flow rate in m³/h at a temperature of 5 to 30 °C and with a pressure loss of 1 bar.

Kv value: $Kv = 0,0396 \cdot \frac{DN^2}{\sqrt{\zeta}}$

Kv flow rate [m³/h]
DN Nominal size [mm]
ζ Pressure loss coefficient taken from table below

Pressure loss: $Ap = \frac{\zeta \cdot v^2}{2 \cdot g}$

Ap Pressure loss [Pa]-10⁵ Pa [^]= 1 bar
ζ Pressure loss coefficient of the valve [taken from diagram]
v Flow velocity relative to DN [m/s]
g 9,81 m/s²

ζ-values (K-values) for ERHARD RKV needle valves DN 400 PN 10, design with vaned ring

Pressure loss coefficients ζ in open position

DN	Seat ring	Vaned ring	Slotted cylinder
100	1,0	1,2	3,1
125	2,7	2,9	8,3
150	1,6	2,4	7,3
200	1,3	1,6	7,6
250	1,9	2,5	8,5
300	1,4	1,9	7,6
350	*	1,5	6,5
400	*	1,5	6,5
450	*	1,5	6,5
500	*	1,5	6,5
600	*	1,5	6,5
700	*	1,5	6,5
800	*	1,4	6,5
900	*	1,4	6,5
1000	*	1,3	*
1200	*	1,1	*
1400	*	1,1	*
1600	*	1,0	*
1800	*	1,0	*

Kvs values (m³/h)

One-piece body			Multipart body		
DN	Vaned ring	Slotted cylinder	DN	Vaned ring	Slotted cylinder
100	365	230	100	*	
125	366	220	125	*	
150	580	330	150	*	
200	1.260	580	200	*	
250	1.580	860	250	*	
300	2.610	1.310	300	*	
			350	4.000	1.900
			400	5.220	2.510
			450	6.610	3.180
			500	8.160	3.920
			600	11.700	5.650
			700	16.000	7.680
			800	21.600	10.040
			900	27.300	12.700
			1000	35.000	*
			1200	54.900	*
			1400	74.700	*
			1600	102.300	*
			1800	129.500	*

Special calculations incorporating the precise installation situation are necessary for the designs marked with an asterisk (*); we would be pleased to perform these calculations for you on the basis of your own data. All values have been determined under practical conditions in ERHARD's in-house test centre.

OPTIMUM ACTUATORS FOR EVERY PURPOSE

A large number of actuator options are available, depending on the mounting position and field of application, and thanks to standardised connections, they can also be easily replaced at any time.

The following actuators can be inserted directly at the end of the actuator **[1]**:

2. Drop weight with float control
3. Drop weight actuator, hydraulic or hydro-electric
4. Double piston part turn actuator, pneumatic or hydraulic

The stem gearbox **[5]** can be directly combined with:

6. Handwheel
7. Square stem cap
8. Headstocks with handwheel and stem extension
9. Headstocks with electric rotary actuator and spindle extension

For use of electric rotary actuators **[10]**, if necessary in combination with spur gearing **[11]**, the stem gearbox is supplemented with a drive flange **[12]**.

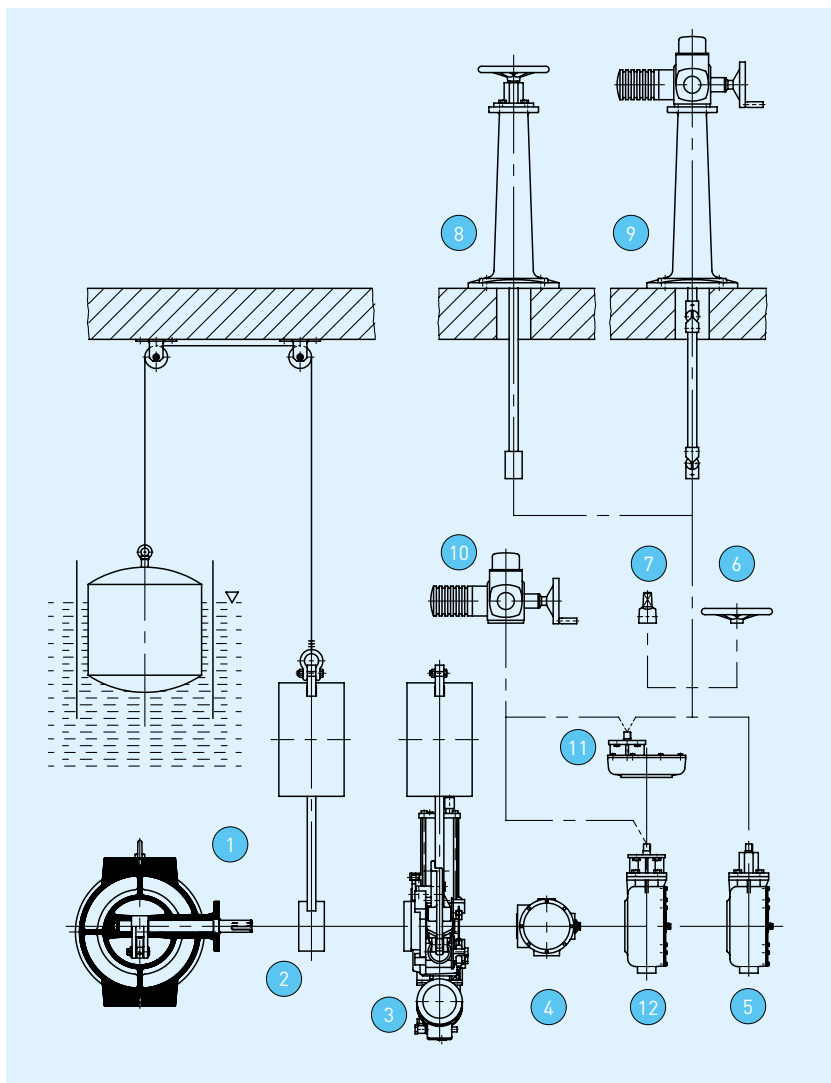

EXPERTISE THROUGH TRADITION PRODUCTS AND SERVICE FROM ERHARD

It was 1871 as the brass caster Johannes Erhard started his business in the small Swabian town of Heidenheim an der Brenz. Since this time, with our valves, we at ERHARD have been helping to ensure that water is available wherever it is needed: in private households, in public facilities, in agriculture or in industrial plant.

Proverbial Swabian inventiveness, the most recent technical findings and experience acquired over 140 years ensure that, with innovative solutions and our wide range of products, we can provide suitable systems for every task. Modern machinery, state of the art and environmentally friendly production methods and high-quality materials enable ERHARD to supply technically advanced, fully developed products with worldwide reputation.

But merely delivering a product is not enough, especially for complex technical installations. And so at ERHARD, highly qualified teams are available in our head office in Heidenheim and in representations in more than 50 countries to give you advice and support in all the life cycle phases.

Planning and design:

- Individual advice
- Development of optimum solutions in dialogue
- In-house laboratory for product tests and trials

Installation and commissioning

- On-site assembly and installation
- Training and instruction

Maintenance and repair

- Inspections and services
- Fast spare part supply
- Repairs on site or in our Heidenheim factory – including third party makes



CONTROL TASKS ALWAYS CORRECTLY SOLVED

Needle products are only one product from the broad ERHARD range of control valves, which includes two basic types:

- Valves controlled by their own medium, which obtain their actuation energy from the flowing medium, e. g. pressure reducing, pressure retention and floating valves
- Valves controlled by external energy, which are actuated electrically, pneumatically, hydraulically, manually or by potential energy as, apart from the needle valve, e. g. the ERHARD REV control valve.

All fulfil the requirements in an optimum way:

- Control characteristics to control large flow ranges
- Removal of pressure differences without generation of cavitation damage
- Low vibrations and quiet energy conversion



ERHARD DVP4 pressure reducing valve



ERHARD DHV4 sustaining valve



ERHARD DVF pressure reducing valve



ERHARD SVP4 float valve



ERHARD pressure and flow control valve



ERHARD ball valve



www.talis-group.com

TALIS is the undisputed Number One for water transport and water flow control. TALIS has the best solutions available in the fields of water and energy management as well as for industrial and communal applications. We have numerous products for comprehensive solutions for the whole water cycle – from hydrants, butterfly valves and knife gate valves through to needle valves. Our experience, innovative technology, global expertise and individual consultation processes form the basis for developing long-term solutions for the efficient treatment of the vitally important resource “water”.



ERHARD GmbH & Co. KG

Postfach 1280

D-89502 Heidenheim

Meeboldstrasse 22

D-89522 Heidenheim

PHONE +49 7321 320-0

FAX +49 7321 320-491

E-MAIL info@erhard.de

INTERNET www.erhard.de

 **TALIS**

Note: Specifications may be changed without notification at any time.
Copyright: No copying without express written permission of ERHARD.
ERHARD is a Registered Trademark. 46033 EN (04/15)